

**VDM® Alloy 602 CA**  
Nicrofer 6025 HT

# VDM® Alloy 602 CA

## Nicrofer 6025 HT

VDM® Alloy 602 CA is a high-temperature material with excellent resistance to creep and oxidation up to 1,200 °C (2,192 °F). VDM® Alloy 602 CA is delivered in the solution-annealed state with an oxidized or descaled surface. The material features to be emphasized are:

- Excellent high-temperature creep behavior values
- Outstanding resistance to oxidation at high temperatures, even under cyclical conditions
- Very good corrosion resistance in carburizing and oxidizing / chlorinating media
- Approval for pressure containers with operating temperatures from -10 to 1,150 °C (14 to 2,102 °F) according to VdTÜV material data sheet 540 and up to 1,650 °F (899 °C) according to ASME Code Section I as well as up to 1,800 °F (982 °C) for applications according to section VIII Div. I.

### Designations and standards

Standard	Material designation
D	2.4633 - NiCr25FeAlY
UNS	N06025

Table 1a – Designations and standards

Product form	DIN	DIN EN	ISO	ASTM	ASME	VdTÜV
Rod, bar	17742 17752	10302	286	B 166	SB 166	540
Sheet, plate	17742 17750	10302		B 168	SB 168	540
Strip	17742 17750	10302		B 168	SB 168	540
Wire	17742			B 166	SB 166	

Table 1b – Designations and standards

# Chemical composition

	Ni	Cr	Fe	C	Mn <sup>1</sup>	Si	Cu	Al	Ti	Y	Zr	P	S
Min.	balance	24	8	0.15				1.8	0.1	0.05	0.01		
Max.		26	11	0.25	0.5	0.5	0.1	2.4	0.2	0.12	0.1	0.02	0.01

<sup>1</sup> The chemical analysis may differ slightly in some elements in other specifications and contain additional elements; according to UNS for example, the value for Manganese is max 0.15 wt.-%.

Table 2 – Chemical composition (%) according to DIN EN 10302

# Physical properties

Density	Melting range	Relative magnetic permeability at 20 °C (68 °F)
7.93 g/cm <sup>3</sup> (0.29 lb/in <sup>3</sup> ) at 25 °C (77 °F)	1,340-1,400 °C (2,444-2,552 °F)	1.01 (Maximum)

Temperature		Specific heat capacity		Thermal conductivity		Electrical resistivity	Modulus of elasticity		Coefficient of thermal expansion	
°C	°F	J Kg · K	Btu lb · °F	W m · K	Btu · in sq. ft · h · °F	μΩ · cm	GPa	10 <sup>3</sup> ksi	10 <sup>-6</sup> K	10 <sup>-6</sup> °F
20	68	447	0.107	10.4	72.2	123	215	31.2		
100	212	465	0.111	12.3	85.3	125	209	30.3	14.15	7.86
200	392	488	0.117	14.0	97.1	126	201	29.2	14.27	7.93
300	572	501	0.120	15.5	107.5	128	197	28.6	14.42	8.01
400	762	514	0.123	16.9	117.3	129	192	27.8	14.63	8.13
500	932	516	0.123	18.4	127.7	131	189	27.4	14.9	8.28
600	1,112	517	0.123	20.1	139.5	133	185	26.8	15.0	8.33
700	1,292	550	0.131	22.0	152.6	132	169	24.5	15.18	8.43
800	1,472	583	0.139	24.1	167.2	131	154	22.3	16.0	8.89
900	1,652	603	0.144	26.2	181.8	131	137	19.9	16.71	9.28
1,000	1,832	626	0.150	28.2	195.7	132	118	17.1	17.31	9.62
1,100	2,012	631	0.151	29.7	206.1		102	14.8	17.91	9.95
1,200	2,192	636	0.152	30.6	212.3					

Table 3 – Typical physical properties at room and increased temperatures.

# Microstructural properties

VDM® Alloy 602 CA has a face-centered cubic lattice. The good mechanical properties, especially at temperatures above 1,000 °C (1,832 °F), are generated by primarily precipitated  $M_{23}C_6$  or  $M_7C_3$  carbides. Additional gamma precipitations can form below 800 °C (1,472 °F).

# Mechanical properties

The following properties of VDM® Alloy 602 CA at room and elevated temperatures apply in the solution-annealed condition and for the specified dimensions.

- Sheet Metal ≤ 50 mm (≤ 1.97 in)
- Strip ≤ 3 mm (≤ 0.12 in)
- Rods and forging ≤ 100 mm (≤ 3.94 in)
- Wire ≤ 12 mm (≤ 0.47 in)

The properties for other dimensions must be agreed separately.

Temperature		Yield strength $R_{p0.2}$		Tensile strength $R_m$		Elongation A
°C	°F	MPa	ksi	MPa	ksi	%
20	68	270	39.2	675	97.9	30
100	212	240	34.8	650	94.3	30
200	392	220	31.9	625	90.6	30
300	572	200	29.0	600	87.0	30
400	752	190	27.6	580	84.1	30
500	932	180	26.1	560	81.2	30
600	1,112	175	25.4	520	75.4	30
700	1,292	170	24.7	420	60.9	30

Table 4 – Minimum short-term properties for material solution annealed at 1,220 °C (2,228 °F) VDM® Alloy 602 CA (particle size ≥ 70 µm) at elevated temperatures according to VdTÜV material data sheet 540

### ISO V-notch impact toughness

Sheet metal up to 50 mm (1.97 in), solution-annealed, at 20 °C (68 °F), grain size ≥ 70 μm, according to VdTÜV material data sheet 540

Transverse: > 56 J/cm<sup>2</sup>

Longitudinal: > 69 J/cm<sup>2</sup>

### Creep resistance

Temperature		Creep limit				Creep strength			
		R <sub>p1.0</sub> /10 <sup>4</sup> h		R <sub>p1.0</sub> /10 <sup>5</sup> h		R <sub>m</sub> /10 <sup>4</sup> h		R <sub>m</sub> /10 <sup>5</sup> h	
°C	°F	MPa	ksi	MPa	ksi	MPa	ksi	MPa	ksi
650	1,202	185	26.8	120	17.4	215	31.2	140	20.3
700	1,292	132	19.1	85	12.3	155	22.5	100	14.5
750	1,382	75	10.9	45	6.5	90	13.1	48	7.0
800	1,472	32	4.6	16.5	2.4	42	6.1	20	2.9
850	1,562	19	2.8	9.7	1.4	26	3.8	14	2.0
900	1,652	13	1.9	7.5	1.1	18	2.6	9.7	1.4
950	1,742	8.8	1.3	5.4	0.8	12.8	1.9	6.7	1.0
1,000	1,832	5.8	0.8	3.4	0.5	9.0	1.3	4.5	0.7
1,050	1,922	3.6	0.5	1.9	0.3	6.2	0.9	3.1	0.5
1,100	2,012	2.2	0.3	1.0	0.1	4.4	0.6	2.1	0.3
1,150	2,102	1.0	0.1	0.4	0.1	3.0	0.4	1.4	0.2
1,200	2,192					2.2	0.3	0.8	0.1

Table 5 – Typical long-term heat resistance values of VDM® Alloy 602 CA in the solution-annealed state. Basic material of VDM® Alloy 602 CA; solution-annealed 1,220 °C (2,228 °F), grain size ≥70 μm according to VdTÜV material data sheet 540

It is found that, when taking the R<sub>p1.0</sub> creep limit (lowest transition temperature) as a basis and while simultaneously considering a safety factor of S = 1.5, long-term heat resistance values for the component design first have to be used for temperatures above approximately 625 °C (1,157 °F). For lower temperatures, higher heat resistance values can be expected (see figure 1).

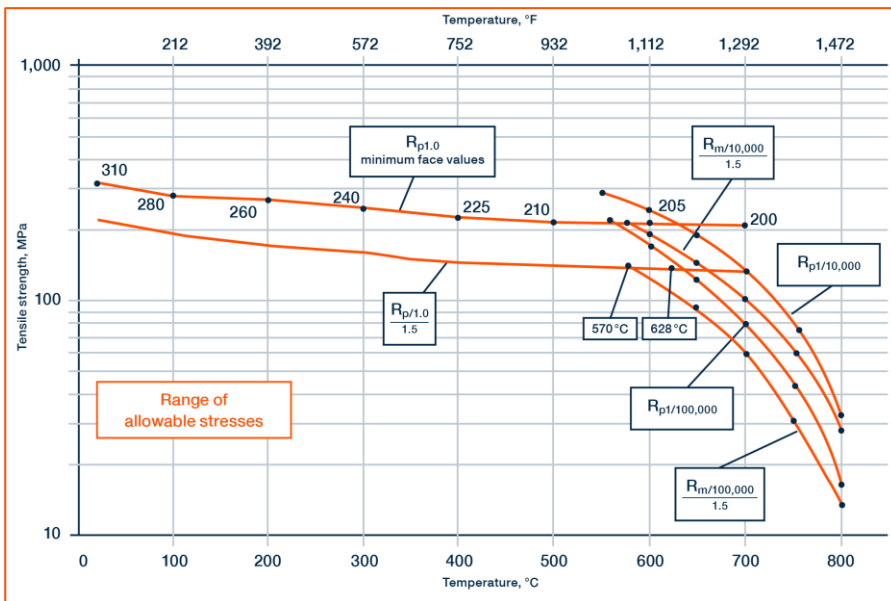

Figure 1 – Intersection of the short-term and long-term strengths of VDM® Alloy 602 CA

# Corrosion resistance

VDM® Alloy 602 CA is especially characterized by very good oxidation resistance, which is better across the entire application range up to 1,200 °C (2,192 °F) than with VDM® Alloy 601. Even under extreme conditions, such as cyclic heating and cooling, VDM® Alloy 602 CA retains this property, which is caused by a tight and adhering alumina layer, which is very resistant to chipping.

High temperature oxidation tests show that, compared to other high temperature materials, this material has the lowest mass loss under cyclic stress. Caused by its chromium and aluminum content, VDM® Alloy 602 CA is also highly resistant in oxidizing sulfur-containing atmospheres at elevated temperatures.

The good resistance of VDM® Alloy 601 against carburizing can be increased even further by VDM® Alloy 602 CA. This also applies to the metal dusting resistance of the material.

# Applications

VDM® Alloy 602 CA has a wide range of application in the high-temperature field of thermotechnical and chemical processes, in power plants and in the automotive industry.

Typical applications are:

- Radiant tubes
- Furnace muffles
- Rotary and shaft furnaces
- Kiln rollers and other furnace installations
- Glass pot for melting radioactive waste
- Methanol and ammonia synthesis
- Hydrogen production
- Reformers in the chemical and petrochemical industries
- Components in automotive exhaust systems
- Glow plugs for diesel engines

# Fabrication and Heat treatment

VDM® Alloy 602 CA can be easily formed both hot and cold and can also be machined.

## Heating

Workpieces must be clean and free of any contaminants before and during heat treatment. Sulfur, phosphorus, lead and other low-melting-point metals can result in damage during the heat treatment of VDM® Alloy 602 CA. This type of contamination can be contained in marking and temperature display paints or pins, and also in lubricating grease, oils, fuels and similar materials. Heat treatment can basically be carried out in gas, oil or electrically heated equipment and also under air admission, protective gas or vacuum. Fuels for directly heated furnaces should have as low a sulfur content as possible. Natural gas with less than 0.1 % and heating oil with maximum 0.5 % sulfur are suitable if a slightly oxidizing furnace atmosphere is set. Reducing or changing conditions should be avoided. The workpiece should not be contacted directly by flames. Ensure that temperature control is precise.

## Hot forming

VDM® Alloy 602 CA can be hot-worked at a temperature range of between 1,200 and 900 °C (2,192 and 1,652 °F) with subsequent rapid cooling down in water or using air nozzles. The workpieces should be placed in the furnace heated up to hot-working temperature in order to heat up. Once the temperature has equalized the workpieces can be removed and worked within the stated temperature window. If the lower temperature limit is fallen below, the workpiece must be reheated. Heat treatment after hot forming is recommended in order to achieve optimal properties.

## Cold forming

The workpieces should be in the solution-annealed condition for cold working. VDM® Alloy 602 CA has a higher work hardening than austenitic stainless steels. This must be taken into consideration when choosing and designing forming equipment and forming processes. Intermediate annealing is necessary for major cold forming work. Solution annealing is to be recommended if deformation degrees over 7 % were reached. When bending and trimming metal sheets, an inner radius should be maintained that is more than three-times the thickness of the metal sheet in order to avoid damage.

## Heat treatment

During each heat treatment, the material is to be inserted into the furnace already heated up to the annealing temperature. The cleanliness requirements listed under the "Heating" section must be observed. VDM® Alloy 602 CA is usually used in the solution-annealed state, where optimal creep strength is a given. VDM® Alloy 602 CA is solution-annealed at 1,220 °C (2,228 °F) for maximum creep strength in order to specifically achieve a particle size of  $\geq 70 \mu\text{m}$ . The retention time during annealing depends on the semi-finished product thickness and can be calculated as follows:

- For thicknesses  $d \leq 10 \text{ mm}$  (0.4 in), the retention time is  $t = d \cdot 3 \text{ min/mm}$
- For thicknesses  $d = 10 \text{ to } 20 \text{ mm}$  (0.4-0.8 in), the retention time is  $t = 30 \text{ min} + (d - 10 \text{ mm}) \cdot 2 \text{ min/mm}$
- For thicknesses  $d > 20 \text{ mm}$  (0.8 in), the retention time is  $t = 50 \text{ min} + (d - 20 \text{ mm}) \cdot 1 \text{ min/mm}$

The retention time commences with material temperature equalization; longer times are generally considerably less critical than retention times that are too short. If additional processes steps take place after the solution annealing, the cooling from the solution annealing temperature should take place at an accelerated speed, e.g. with water or with compressed air (for metal sheets less than 3 mm (0.12 in) thickness). If solution annealing is the last processing step before use, cooling can be carried out more slowly in order to avoid warpage. Solution-annealed VDM® Alloy 602 CA is sensitive to stress relaxation cracks in a range between 600 and 750 °C (1,112 and 1,382 °F) and should therefore be stabilization-annealed if permanent deployment (>100 h) is to take place in the aforementioned temperature range. Stabilization-annealing should be carried out before or after welding work. In addition, VDM® Alloy 602 CA should be stabilization-annealed before repair welding. Stabilization-annealing should be carried out at 950 °C (1,742 °F) for at least three

hours. Heating-up and cooling-down speeds are not critical in this case and should not be too high in order to avoid warping.

For strip products, the heat treatment can be performed in a continuous furnace at a speed and temperature that is adapted to the strip thickness.

#### **Descaling and pickling**

High-temperature materials develop a protective oxide layer in service. The necessity for descaling should therefore be checked on ordering.

Oxides from VDM® Alloy 602 CA and tempering colors in the area around welds have better bonding than in stainless steels. Grinding using extremely fine abrasive belts or grinding discs is recommended. Tempering colors caused by grinding (grinding burn) should be avoided. If pickling is to be carried out, the pickling times (as for all high-temperature materials) should be kept short because they can otherwise be subject to inter-crystalline attack. Furthermore, the temperature must be scrupulously observed. Before pickling in nitric-hydrofluoric acid mixtures, the oxide layers should be destroyed by abrasive blasting or fine grinding, or pre-treated in molten salts.

#### **Stock removal machining**

VDM® Alloy 602 CA is preferably processed in a solution-annealed condition. Since the alloy is prone to work-hardening, a low cutting speed should be selected with a feed speed that is not too high. The cutting tool should be engaged at all times. An adequate depth of cut is important in order to cut below the previously formed strain-hardened zone. The strong heat development during machining should be countered by a sufficient amount of cooling lubricant. Water-based emulsions such as those used for structural and stainless steels are very suitable for this purpose. Suitable cutter geometries, suitable cutter materials and cut values can be taken from the VDM metals publication N 579 entitled "Processing information for austenitic stainless steels and nickel-based alloys".

## **Welding information**

When welding nickel alloys and special stainless steels, the following information should be taken into account:

#### **Workplace**

A separately located workplace, which is specifically separated from areas in which C steel is being processed, must be provided. Maximum cleanliness is required, and drafts should be avoided during gas-shielded welding.

#### **Auxiliary equipment and clothing**

Clean fine leather gloves and clean working clothes must be used.

#### **Tools and machines**

Tools that have been used for other materials may not be used for nickel alloys and stainless steels. Only stainless steel brushes may be used. Processing and treatment machines such as shears, punches or rollers must be fitted (felt, cardboard, films) so that the workpiece surfaces cannot be damaged by the pressing in of iron particles through such equipment, as this can lead to corrosion.



### Welding edge preparation

Welding edge preparation should preferably be carried out using mechanical methods such as lathing, milling or planing. Abrasive waterjet cutting or plasma cutting is also possible. In the latter case, however, the cut edge (seam flank) must be cleanly reworked. Careful grinding without overheating is also permissible.

### Striking the arc

The arc may only be struck in the seam area, e.g. along the seam flanks or a shoe, and should not be carried out on the component surface. Areas where firing takes place are more susceptible to corrosion.

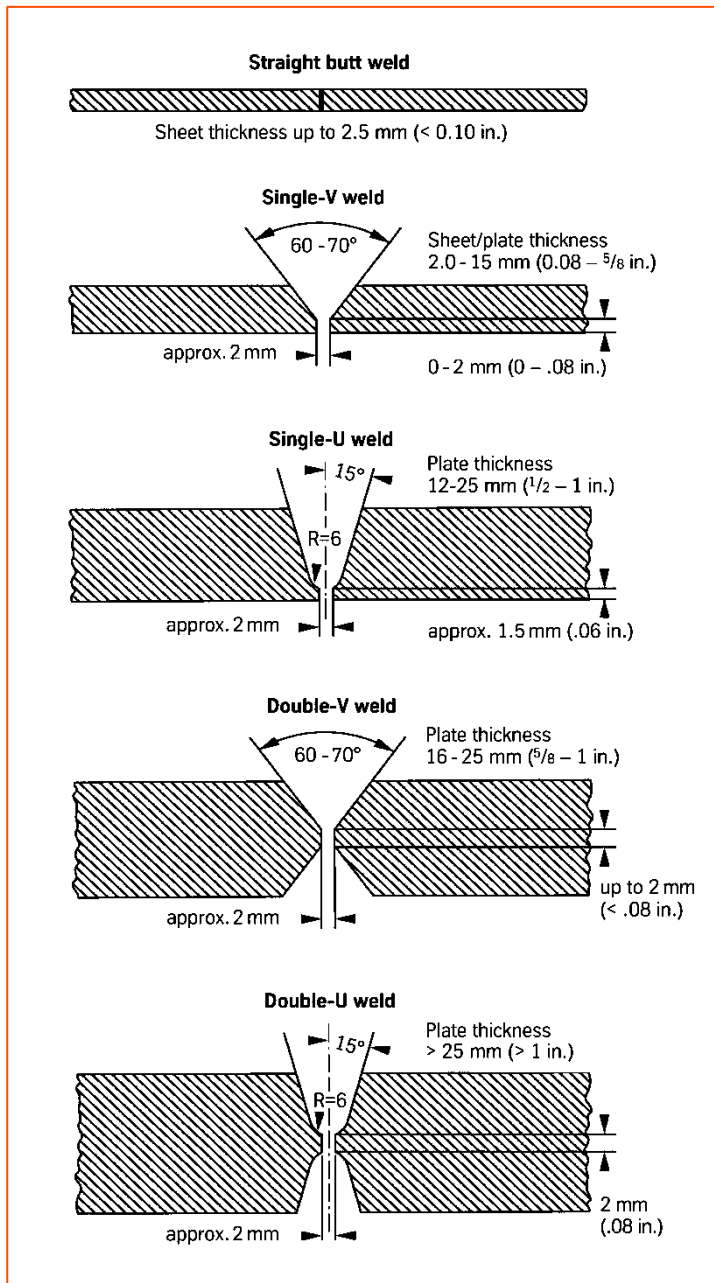

Figure 2 – Seam preparation for welding nickel alloys and special stainless steels

### Included angle

Compared to C-steels, nickel alloys and specialty stainless steels have a lower heat conductivity and greater heat expansion. Larger root gaps and web spacing (1 to 3 mm, 0.039 to 0.118 in) are required to live up to these properties. Due to the viscosity of the melting (compared to standard austenites) and the tendency to shrink, included angles from 60 to 70° – as shown in Figure 2 – have to be provided for butt welds.

**Cleaning**

Cleaning of the basic material in the seam area (both sides) and the filler material (welding rod) should be carried out using acetone.

**Welding parameters and influences**

It must be ensured that work is carried out using targeted heat application and low heat input as shown in table 6 as an example. The stringer bead technique is recommended. The interpass temperature should not exceed 120 °C (248 °F). In principle, it is necessary to check the welding parameters.

Heat input Q can be calculated as follows:

$$Q = \frac{U \cdot I \cdot 60}{v \cdot 1,000} \left( \frac{\text{kJ}}{\text{cm}} \right)$$

U = arc voltage, volts

I = welding current strength, amperes

v = welding speed, cm/minute

**Welding filler**

It is recommended to use the same type of welding filler for welding:

VDM® FM 602 CA (W. no. 2.4649)

DIN EN ISO 18274: S Ni 6025

(NiCr25Fe10AlY)

UNS N06025

AWS A5.14: ERNiCrFe-12

The use of bar electrodes in sleeves is possible.

**Post-treatment**

If the work is performed optimally, brushing immediately after welding, i.e. while still warm, and without additional pickling, this will result in the desired surface condition. In other words, annealing colors can be removed completely. Pickling, if required or specified, should generally be the last operation in the welding process. The information contained in the section entitled "Descaling and pickling" must be observed. Usually preheating before welding is not required. Are welded components of VDM® Alloy 602 CA being used at temperatures of between 600 to 750 °C (1,112 to 1,382 °F), stabilizing annealing may be necessary. Stabilizing annealing should also be carried out on components that have already been used before they are used in this critical temperature range again after a repair welding.

Thickness (mm)	Welding technique	Filler material		Root pass <sup>1)</sup>		Intermediate and final passes		Welding speed (cm/min)	Shielding gas <sup>5)</sup>	
		Diameter (mm)	Speed (m/min)	I in (A)	U in (V)	I in (A)	U in (V)		Type	Rate (l/min)
2	manual TIG	2.0	-	90-100	11	-	-	10-15	Ar with 2% N2	8-10
6	manual TIG	2.0-2.4	-	110	11	130-150	15	10-15	Ar with 2% N2	8-10
12	manual TIG	2.4	-	110	11	130-150	15	10-15	Ar with 2% N2	8-10
3	autom. TIG <sup>2)</sup>	0.8-1.2	1.0-2.5	-	-	150-250	10-15	20-30	Ar with 2% N2	15-20
8	autom. TIG <sup>2)</sup>	0.8-1.2	1.0-2.5	-	-	150-250	10-15	20-30	Ar with 2% N2	15-20
5	Plasma <sup>3)</sup>	1.0-1.2	1.0	200-220	26	-	-	25-30	Ar with 2% N2	30
12	Plasma <sup>3)</sup>	1.0-1.2	1.0	220-240	26	-	15	24-30	Ar with 2% N2	30
≥ 8	GMAW <sup>4)</sup>	1.0-1.2	5.0	-	-	130-140	23-27	24-30	Z-ArHeNC 10-5-0.05	16-20

<sup>1)</sup> It must be ensured that there is sufficient root protection, for example using Ar 4.6, for all inert gas welding processes.

<sup>2)</sup> The root pass should be welded manually (see manual TIG).

<sup>3)</sup> Recommended plasma gas Ar 4.6 / rate 3.0 to 3.5 l/min

<sup>4)</sup> For MAG welding the use of multicomponent inert gases is recommended.

<sup>5)</sup> The listed inert gases should be used for welding with filler material VDM® FM 602 CA.

Section energy kJ/cm:

TIG, GMAW manual, mechanized max. 8; manual metal arc welding max. 7; Plasma max. 10

Figures are for guidance only and are intended to facilitate setting of the welding machines.

Table 6 - Welding parameters

# Availability

VDM® Alloy 602 CA is available in the following semi-fabricated forms:

## Rod and bar

Delivery condition: Forged, rolled, drawn, heat treated, oxidized, descaled or pickled, turned, peeled, ground or polished.

Dimensions *	Outside diameter mm (in)	Length mm (in)
General dimensions	6-800 (0.24-31.50)	1,500-12,000 (59.06-472.44)
Material specific dimensions	8-400 (0.31-15.75)	1,500-12,000 (59.06-472.44)

\* Further dimensions on request.

## Sheet and plate

Delivery condition: Hot or cold-rolled, heat-treated, de-scaled or pickled

Condition	Thickness mm (in)	Width mm (in)	Length mm (in)	Piece weight Kg (lb)
Cold rolled	1-7 (0.04-0.28)	≤ 2,500 (98.43)	≤ 12,500 (492.13)	
Hot rolled*	3-50 (0.12-1.97)	≤ 2,500 (98.43)	≤ 12,500 (492.13)	≤ 1,750 (3,858)

Sheets can be manufactured considering the minimum and maximum dimensions

\* 2 mm (0.08 in) thickness on request

## Strip

Delivery condition: Cold-rolled, heat-treated, pickled or bright annealed

Thickness mm (in)	Width mm (in)	Coil - inside diameter mm			
0.025-0.15 (0.001-0.006)	4-230 (0.16-9.06)	300	400	500	–
0.15-0.25 (0.006-0.01)	4-720 (0.16-28.34)	300	400	500	–
0.25-0.6 (0.01-0.024)	6-750 (0.24-29.5)	–	400	500	600
0.6-1 (0.024-0.04)	8-750 (0.32-29.5)	–	400	500	600
1-2 (0.04-0.08)	15-750 (0.6-29.5)	–	400	500	600
2-3 (0.08-0.12)	25-750 (0.98-29.5)	–	400	500	600

Rolled sheet – separated from the coil – are available in lengths from 250 to 4,000 mm (9.84 to 157.48 in).

## Wire

Delivery condition: Drawn bright, ¼ hard to hard, bright annealed in rings, containers, on spools and spiders.

Drawn mm (in)	Hot rolled mm (in)
0.16-10 (0.006-0.4)	5.5-19 (0.22-0.75)

Other shapes and dimensions available on request.

# Technical publications

The following technical literature has been published about VDM® Alloy 602 CA:

U. Brill: "Korrosion und Korrosionsschutz – Nickel, Cobalt und Nickel und Cobalt-Basislegierungen", in Egon Kunze (Hrsg.), Sonderdruck aus Band 2: "Korrosion der verschiedenen Werkstoffe", WILEY-VCH Verlag, Weinheim, 1992.

U. Brill, D. C. Agarwal: „Alloy 602 CA, a new high-strength, high-temperature alloy for service temperatures up to 1200 °C“, CORROSION '93, Paper No. 226, NACE International, Houston, Texas, 1993.

D. C. Agarwal, U. Brill, M. Metzler: „Practical Experience with the New Alloy 602 CA (NiCr25FeAlY) – Applications in Heat Treat Industry“, in CORROSION '93, Paper No. 235, NACE International, Houston, Texas, 1993.

U. Brill: „Eigenschaften und Einsatzgebiete der neuen Legierung VDM® Alloy 602 CA“, Zeitschrift Stahl 1994, S. 32-35.

D. C. Agrawal, U. Brill: „Material degradation problems in high-temperature environments (alloys-alloying effects-solutions)“ Industrial Heating, October 1994.

D.C. Agarwal, U. Brill, O. Ibas: „Corrosion Behaviour of Some High-Temperature Alloys Under High Velocity Burnt Fuel“, Proc. 2. Int. Conf. on High Resistance Materials, Gatlinburg, Tennessee, 1995.

U. Brill, D. C. Agarwal: „Alloy 602 CA – A New Alloy for the Furnace Industry“, Proc. 2. Int. Conf. on High Resistance Materials, Gatlinburg, Tennessee, 1995.

D. C. Agarwal, U. Brill, H.-W. Kettler, G. Giersbach: „Innovations in Alloy Metallurgy for Furnace Rolls and Other High Temperature Applications“, Proc. 2. Int. Conf. on High Resistance Materials, Gatlinburg, Tennessee, 1995.

U. Brill: „Aluchrom- und VDM® Alloy 602 CA-Katalysatorband für umweltfreundliche Kraftfahrzeuge“, Zeitschrift Blech Rohre Profile 1995, S. 770 – 772.

U. Brill, G. Giersbach, H.-W. Kettler: „Effizienzsteigerung kontinuierlicher Wärmebehandlungsanlagen durch den Einsatz ungekühlter Ofenrollen aus dem neuen Werkstoff VDM® Alloy 602 CA (2.4633)“, VDI-Berichte Nr. 1151, 1995, S. 65-88.

U. Brill: „Praktische Erfahrung mit dem neuen Werkstoff VDM® Alloy 602 CA (2.4633) im Ofen- und Wärmebehandlungsanlagebau“, Zeitschrift Stahl 1995.

U. Brill, M. Metzler, J. Claus: „Leistungsverbesserung von Emailieranlagen durch den Einsatz des neuen Werkstoffs VDM® Alloy 602 CA“, Mitteilung des Deutschen Email Verbandes, 1996, S. 7-10.

U. Brill: „Schweißverhalten und Eigenschaften der artgleichen Schweißverbindung des hochwarmfesten Ofenbauwerkstoffes VDM® Alloy 602 CA (W.-Nr. 2.4633)“, Internationale Konferenz Schweißtechnik, Werkstoffe und Werkstoffprüfung, Bruchmechanik und Qualitätsmanagement, TU Wien, 1997, S. 237-256.

U. Brill, J. Klöwer: Vergleichende Untersuchung des Oxidationsverhaltens der Werkstoffe VDM® Alloy 602 CA 7216 H, 6023 H“, Zeitschrift Metall 1997, S. 263-266.

O. Ibas, U. Brill: „Einfluß der Auslagerungstemperatur und -zeit auf die Zähigkeit von ausgewählten Nickelbasislegierungen“, Werkstoffprüfung 1998, S. 137-144.

U. Brill, M. Rockel: „Hochtemperaturwerkstoffe der Krupp VDM für den Anlagenbau“, VDM Report Nr. 25, 1999.

U. Brill: „Neue Ergebnisse mit dem Werkstoff VDM® Alloy 602 CA im Ofen- und Wärmebehandlungsanlagenbau“, Zeitschrift Stahl 1999, S. 54-56.

D. C. Agarwal und U. Brill: „Performance of alloy 602 CA (UNS N06025) in hightemperature environments up to 1200 °C”, CORROSION 2000, Paper No. 521, NACE International, Houston, Texas, 2000.

D. C. Agarwal und U. Brill: “High-temperature strength nickel alloy”, Advanced Materials & Processes, 2000.

D. C. Agarwal, U. Brill and J. Klöwer: “Recent results on metal dusting of nickel-base alloys and some applications”, CORROSION 2001, Paper No. 382, NACE International, Houston, Texas, 2001.

J. Wilson, D.C. Agarwal: “Case histories on successful applications of alloy 602 CA,UNS N06025 in high temperature environments”, CORROSION 2005, Paper No. 5423, NACE International, Houston, Texas, 2005.

# Legal notice

16 January 2017

## **Publisher**

VDM Metals International GmbH  
Plettenberger Strasse 2  
58791 Werdohl  
Germany

## **Disclaimer**

All information contained in this data sheet is based on the results of research and development work carried out by VDM Metals International GmbH and the data contained in the specifications and standards listed available at the time of printing. The information does not represent a guarantee of specific properties. VDM Metals reserves the right to change information without notice. All information contained in this data sheet is compiled to the best of our knowledge and is provided without liability. Deliveries and services are subject exclusively to the relevant contractual conditions and the General Terms and Conditions issued by VDM Metals International GmbH. Use of the most up-to-date version of this data sheet is the responsibility of the customer.

VDM Metals International GmbH  
Plettenberger Strasse 2  
58791 Werdohl  
Germany

Phone +49 (0)2392 55 0  
Fax +49 (0)2392 55 22 17

[vdm@vdm-metals.com](mailto:vdm@vdm-metals.com)  
[www.vdm-metals.com](http://www.vdm-metals.com)